

WALL BRACKET INSTALLATION INSTRUCTION SHEET

McSort Bracket #330001

Quickly and easily adapt the McSort Paper Flow Management System to mount on any wall using our #330001 bracket.

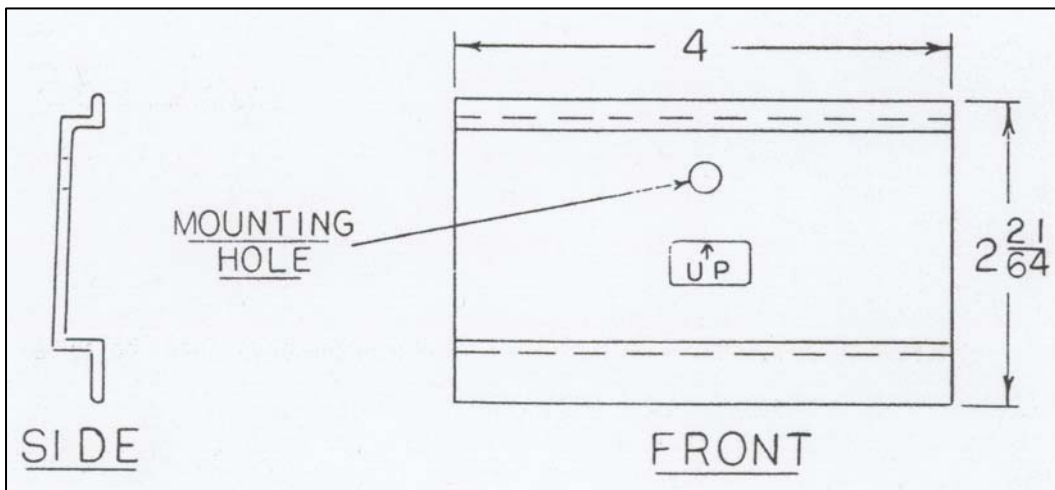

BEFORE YOU BEGIN:

Wall Brackets are supplied with $\frac{1}{4}$ " x 1" lag screws for wall mounting. As mounting surfaces may vary however, it is the user's responsibility to be certain that the brackets are **securely** fastened to the wall using any additional screws, drywall anchors, toggle bolts, etc., that may be necessary. Such items are readily available at most hardware stores.

Failure to mount the brackets securely to the wall could result in the load bar and attached accessories falling causing damage and possible injury.

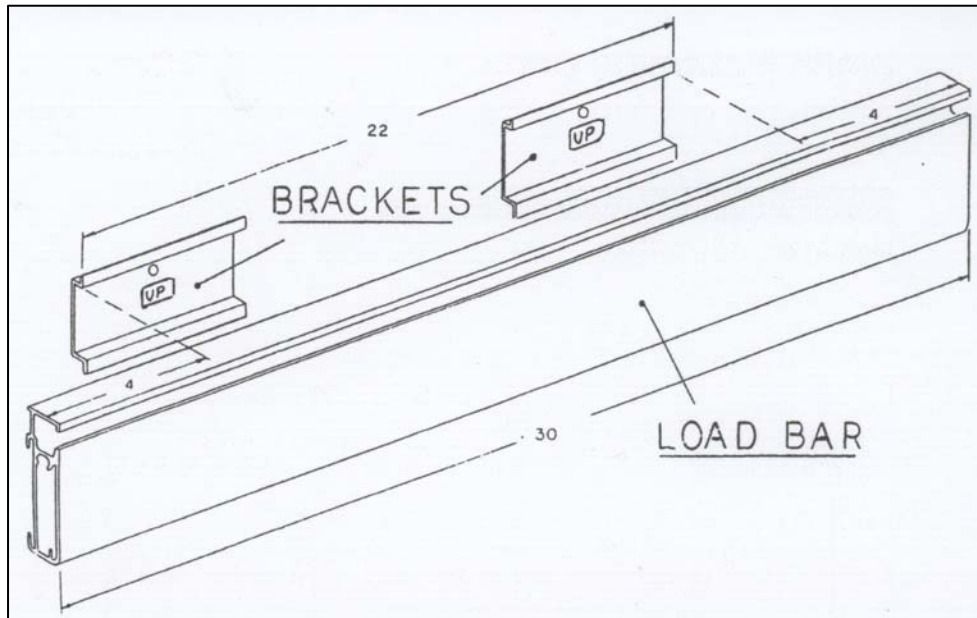

STEP 1: Position the Wall Mounting Brackets so that they are approximately 4" in from each end of the load bar that is to be attached. Firmly secure following the guidelines presented earlier.

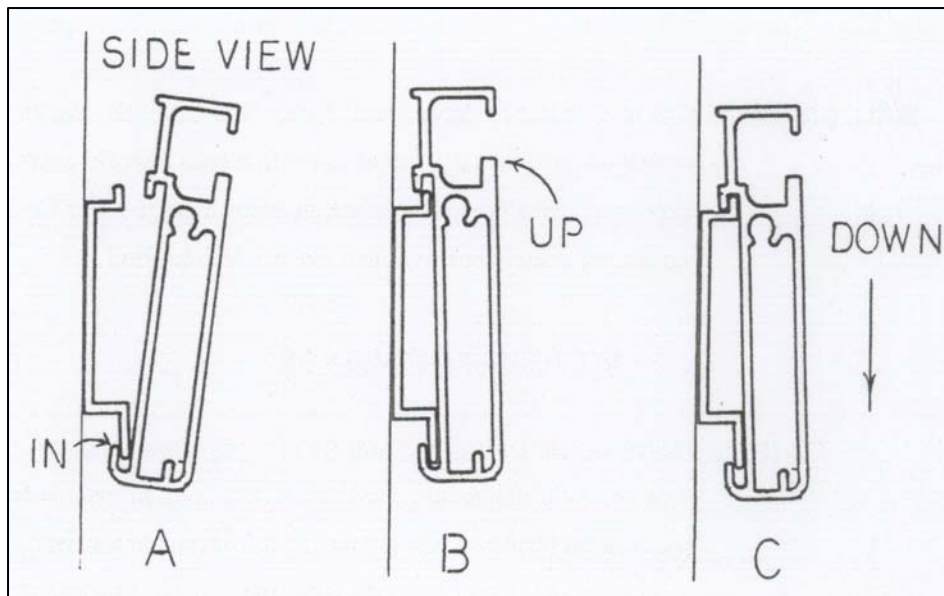

STEP 2: Attach the load bar by hooking the bottom to the bottom of the brackets (A), swinging the top into position over the top of the brackets (B), and then pushing down to establish a firm connection with the brackets (C).

STEP 3: Attach end caps. McSort accessories may now be attached.